

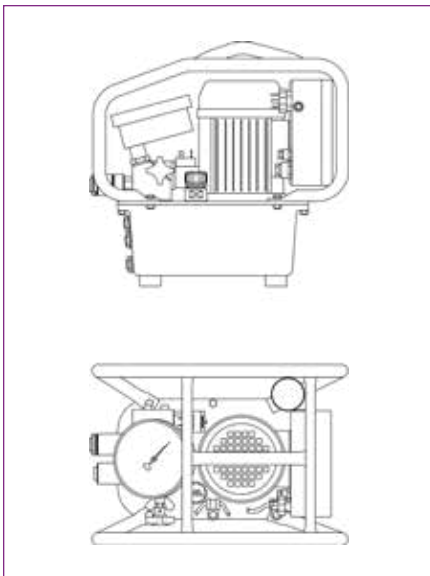

JETPRO-S-115-CSA

The JETPRO 2-stage Hydraulic Power System is the most affordable lightweight pump on the market. The JETPRO's compact design and one-gallon reservoir alleviates weight restrictions like no other hydraulic pump which offers the operator efficient mobility. Simple two-button controls ensure the operator's ease of use while also speeding up the bolting process. The JETPRO operates at a very quiet ~80 dB.



PUMP SPECIFICATIONS AND FEATURES

Power	115v (7.5 Amp) / 230v (4.5 Amp)
Gauge	0-10 k PSI (+/-1% Accuracy)
Reservoir Capacity	0.8 gals. / 3.0 l
Stages	2
Weight	33 lbs. / 15 kg
Maximum Oil Flow Rate	310 cu. in./min. / 5 l/min.
Oil Cooler	No
Protective Caging	Yes
15' Remote Control	Yes
15' Twin Line Steel Braided Hydraulic Hose	Yes



HYTORC MISSION STATEMENT

HYTORC'S MISSION IS TO OPTIMIZE SAFETY, QUALITY AND SCHEDULE IN INDUSTRIAL BOLTING THROUGH INNOVATIVE SOLUTIONS, AND AN UNYIELDING COMMITMENT TO WORLD-CLASS CUSTOMER SERVICE.

MOBILE SERVICES



Mobile service, maintenance, and on-site training to get you and your tools back on the job faster than ever before.

WORLDWIDE SERVICE



The HYTORC Universe is made up of over 1,000 trained bolting specialists to support your bolting needs in over 100 countries.

THE HYTORC STANDARD



With over 50 years of experience focused entirely on developing the highest quality industrial bolting systems, HYTORC remains committed to higher performance and service and offers superior technology, quality, and support.

The World's Most Trusted Industrial Bolting Systems

HYTORC owns all content, copyrights, trademarks and patents in this document. © 2021 HYTORC. Any unauthorized use or distribution of any material from this document is strictly prohibited.

HYTORC
Western Canada

Western Canadian Head Office:

45 Corriveau Avenue
St. Albert, AB T8N 5A3

Phone:

1-877-235-4733

Email:

info@hytorcwest.ca

Online:

hytorcwest.ca