

HY-AIR

Our HY-AIR is a 4-stage pump designed to reduce cycle time and improve productivity. A compact design with an optional one or two-gallon reservoir alleviates weight restrictions and offers the operator efficient mobility. Simple controls make for short set-up times and the semi-automatic feature allows the operator to experience faster and easier bolting.

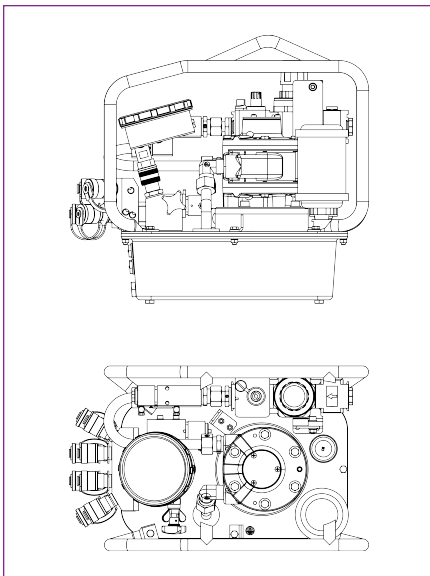

PUMP SPECIFICATIONS AND FEATURES

Power	3,800 cu.in./sec. (62 l/sec.)
Gauge	0-10 k PSI (+/-1% Accuracy)
Reservoir Capacity	1.35 gals. / 5.1 l (2 gals. / 7.6 l tank optional for the HY-115)
Stages	4
Weight	46.3 lbs. / 21 kg
Maximum Oil Flow Rate	770 cu. in./min. / 13 l/min.
Oil Cooler	Yes
Protective Caging	Yes
15' Remote Control	Yes